

Q series

QM5

Multi-Deck Merchandiser

KYSOR
WARREN®



QM5 - meat configuration with e-line trim level

We Listen, Respond... and Deliver!

Optimum merchandising flexibility is the mainstay of the QM5. The case is designed for red meat and deli products, eliminating the need for different case models in the same lineup. The large, efficient coil, coupled with a positive air curtain, maintains even and proper temperatures in the well and upper shelf areas. The beautiful, modern design of the QM5 case will blend with any store decor.

KEY FEATURES:

- Energy Efficient Operation**
- Heavy Duty Front Bumper**
- Aluminum Bottom Liner**
- Non CFC Foam Insulation**
- Aluminum Finned-Copper Tubed Coil**
- Under Case Air Return**



Applications

QM5, QM5G

Multi-Deck Merchandiser



QM53 (3000 SERIES)



QM51 (2500 SERIES)



QM53 (3000 SERIES)

Capacities	4'	6'	8'	12'
QM5 Facing Area	17.7 ft ²	26.4 ft ²	35.3 ft ²	52.9 ft ²
QM5 Cubic Capacity	38.0 ft ³	56.9 ft ³	76.0 ft ³	113.9 ft ³
Dimensions	4'	6'	8'	12'
Overall Length (w/o ends)	48.25"	72.25"	96.375"	144.5"
Thickness - Pair Ends	3"	3"	3"	3"
Case Data	4'	6'	8'	12'
Anti-Sweat Amps	N/A	N/A	N/A	N/A
Fan Amps Std	0.52	0.70	1.04	1.56
Light Amps (T8 light bulbs/single row canopy)	0.25	0.40	0.50	0.75
Evaporator Temperature (°F)	23	23	23	23
QM5(G) Btu/Hr Requirements	5580	8370	11160	16740

Defrost	Per Day	Fail Safe	Termination
Off Cycle / Electric	3	35 min.	48 °F
Hot Gas	3	20 min.	48 °F

Discharge Air Velocity	Discharge Air Temperature
225 FPM	29 °F

All electrical data are based on 115V and unlighted shelves.

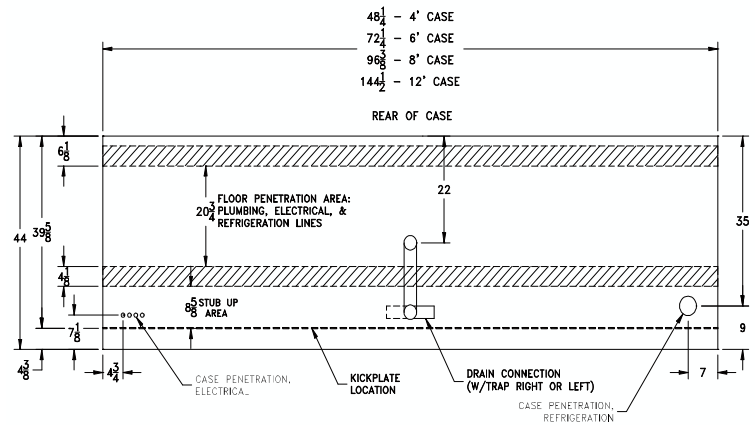
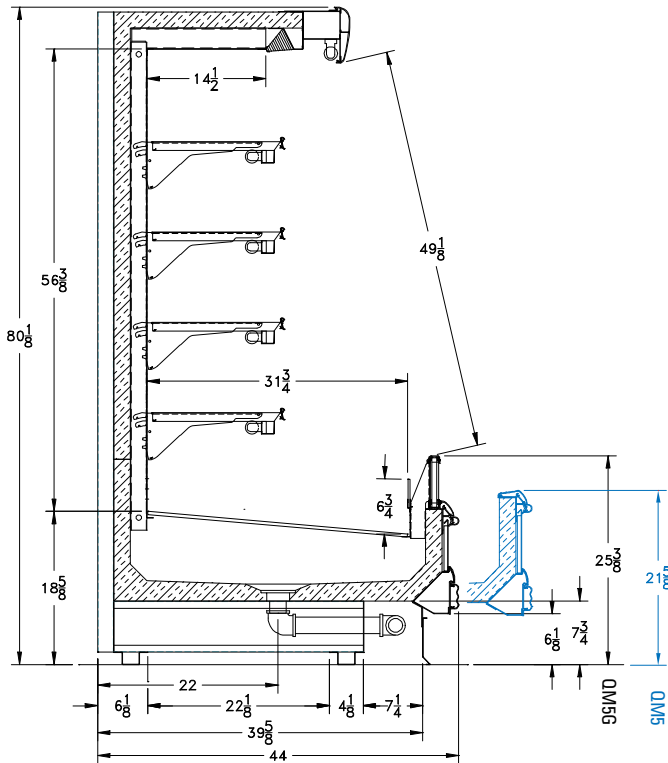

Enodis® One Company. Countless Solutions.

KYSOR // WARREN

Type I refrigerator, intended for use in an area where the environmental conditions are controlled and maintained such that conditions do not exceed 75°F and 55% relative humidity. Kysor/Warren, whose policy is one of continuous improvement, reserves the right to change at any time, specifications, design or prices without incurring obligation.

5201 Transport Blvd. / Columbus, GA 31907
800-866-5596 - Phone / 706-568-8990 - Fax / solutions@kysorwarren.com

Dual-Jet and Air Defrost are registered trademarks of Kysor/Warren.
Kysor/Warren, a subsidiary of Enodis®, PLC. All Rights Reserved.

Kysor/Warren cases are UL and NSF listed.



QM5-0805PD