

Q series

QM4A

Multi-Deck Merchandiser

KYSOR
WARREN®



QM4A - meat configuration with e-line trim level

We Listen, Respond... and Deliver!

High product visibility and efficiency are the key features of the multi-purpose QM4A. The case is designed for both red meat and deli products thus offering a standard case appearance that will beautifully blend with any store decor. The QM4A offers tremendous cost saving opportunities.

KEY FEATURES:

- Energy Efficient Operation**
- Heavy Duty Front Bumper**
- Aluminum Bottom Liner**
- Non CFC Foam Insulation**
- Aluminum Finned-Copper Tubed Coil**
- Under Case Air Return**



Applications

QM4A, QM4AL

Multi-Deck Merchandiser



QM4A3 (3000 SERIES)



QM4A1 (2500 SERIES)



QM4A3 (3000 SERIES)

Capacities	4A	6A	8A	12A
QM4A Facing Area	13.1 ft ²	19.6 ft ²	26.1 ft ²	39.1 ft ²
QM4A Cubic Capacity	32.4 ft ³	48.6 ft ³	64.8 ft ³	97.2 ft ³
Dimensions	4A	6A	8A	12A
Overall Length (w/o ends)	48.25"	72.25"	96.375"	144.5"
Thickness - Pair Ends	3"	3"	3"	3"
Case Data	4A	6A	8A	12A
Anti-Sweat Amps	N/A	N/A	N/A	N/A
Fan Amps Std	0.52	0.70	1.04	1.56
Light Amps (T8 light bulbs/single row canopy)	0.25	0.40	0.50	0.75
Evaporator Temperature (°F)	24	24	24	24
QM4A Btu/Hr Requirements	4880	7320	9760	14640
QM4AL Btu/Hr Req @ +23°F	5600	8400	11200	16800

Defrost	Per Day	Fail Safe	Termination
Off Cycle/Electric	4-6	35 min.	48 °F
Hot Gas	4-6	20 min.	48 °F

Discharge Air Velocity	Discharge Air Temperature
250 FPM	29 °F

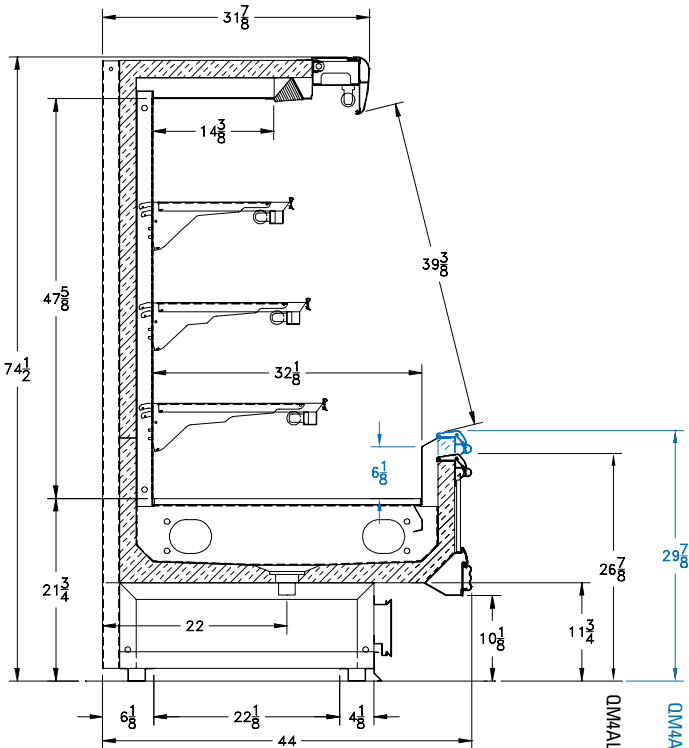

All electrical data are based on 115V and unlighted shelves.

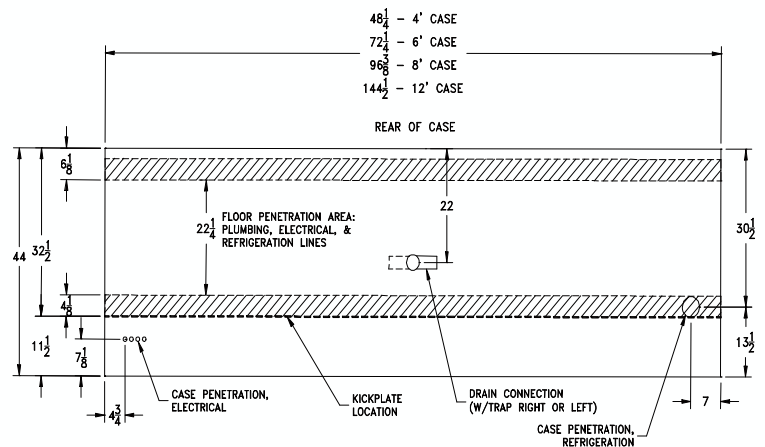

Enodis® One Company. Countless Solutions.

KYSOR // WARREN

Type I refrigerator, intended for use in an area where the environmental conditions are controlled and maintained such that conditions do not exceed 75°F and 55% relative humidity. Kysor/Warren, whose policy is one of continuous improvement, reserves the right to change at any time, specifications, design or prices without incurring obligation.



Dual-Jet and Air Defrost are registered trademarks of Kysor/Warren. Kysor/Warren, a subsidiary of Enodis®, PLC. All Rights Reserved.

Kysor/Warren cases are UL and NSF listed.

QM4A-0805PD

5201 Transport Blvd. / Columbus, GA 31907
800-866-5596 - Phone / 706-568-8990 - Fax / solutions@kysorwarren.com