

e line

NS39V

Double Curved Fixed Glass
Service Merchandiser



NS39V1 - e-Line trim level

We Listen, Respond... and Deliver!

The NS39V1 offers unmatched product appeal with its optional double pane, double curved fixed front glass. The innovative style and design permits appetizing displays of fresh meats, deli or seafood.

KEY FEATURES:

- Non CFC Foam Insulation**
- Gravity Coil**
- Stainless Steel Bottom Liner**
- Heavy Duty Front Bumper**
- Aluminum Finned-Copper Tubed Coils**
- Large Rear Service Doors**

KYSOR / **WARREN**



Applications

NS39V

Double Curved Fixed Glass Merchandiser



NS39VL3 (3000 SERIES)



NS39V1 (2500 SERIES)

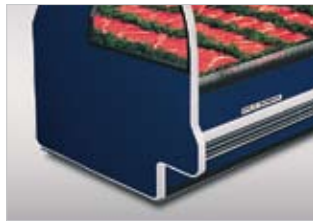

NS39V3 (3000 SERIES)

Capacities	4'	6'	8'	12'
Facing Area	8.4 ft ²	12.6 ft ²	16.9 ft ²	29.3 ft ²
Cubic Capacity	14.6 ft ³	22 ft ³	29.3 ft ³	43.9 ft ³
Dimensions	4'	6'	8'	12'
Overall Length (w/o ends)	48.19"	72.25"	96.375"	144.5"
Thickness - Pair Ends	3"	3"	3"	3"
Case Data	4'	6'	8'	12'
Anti-Sweat Amps	N/A	N/A	N/A	N/A
Fan Amps Std	N/A	N/A	N/A	N/A
Light Amps	0.43	1.04	1.04	1.68
Def. Load Amps (if electric)	N/A	N/A	N/A	N/A
Evaporator Temperature (°F)	+20°	+20°	+20°	+20°
BTU/Hr Requirements	1280	1920	2560	3840

Defrost	Per Day	Fail Safe	Termination
Off Cycle - NS39V	1	80 min.	TIME

Discharge Air Velocity	Discharge Air Temperature
Gravity	N/A

All electrical data are based on 115V and unlighted shelves.

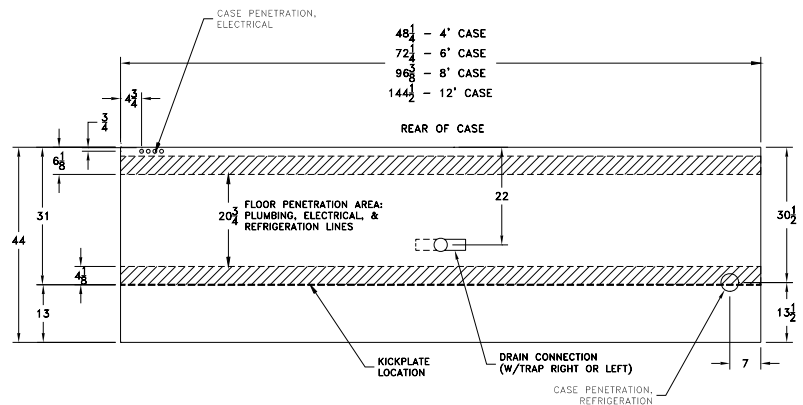
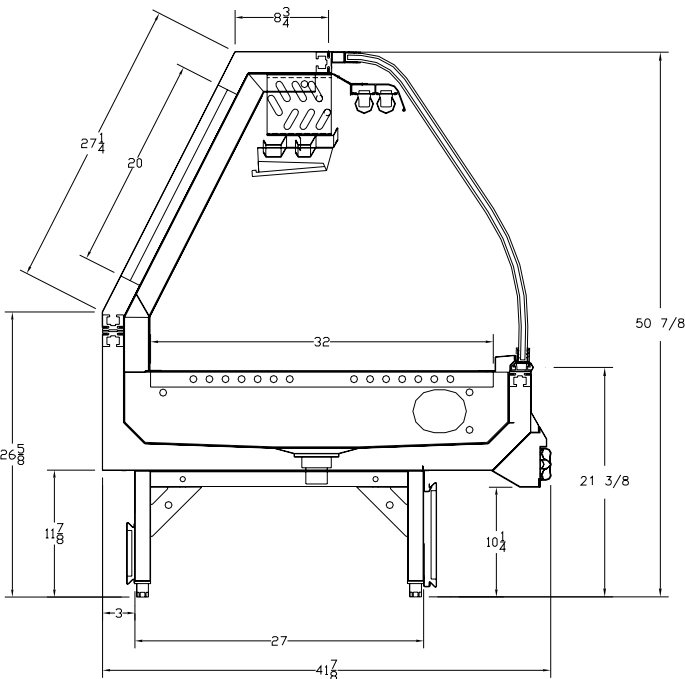

Enodis® One Company. Countless Solutions.



Type I refrigerator, intended for use in an area where the environmental conditions are controlled and maintained such that conditions do not exceed 75°F and 55% relative humidity. Kysor/Warren, whose policy is one of continuous improvement, reserves the right to change at any time, specifications, design or prices without incurring obligation.

5201 Transport Blvd. / Columbus, GA 31907
800-866-5596 - Phone / 706-568-8990 - Fax / solutions@kysorwarren.com

Dual-Jet and Air Defrost are registered trademarks of Kysor/Warren.
Kysor/Warren, a subsidiary of Enodis®, PLC. All Rights Reserved.

Kysor/Warren cases are UL and NSF listed.



NS39V-0805PD